

zumoval
JUICERS FOR LIFE

Fresh
Juice
HERE!





Founded in 1991, Zumoval is nowadays one of the leading international manufacturers of automatic juicers.

We offer strong, fast and reliable citrus and pomegranate juicers that have gained extensive international recognition.

At Zumoval we manufacture our products according to strict quality criteria following the most demanding international standards. That is why our products have the most recognized certifications.



Zumoval juicers are the strongest and most reliable juicers on the market.

Our machines are equipped with steel gears and shafts, a robust aluminum sumpt, very high-quality food-grade materials and a powerful 0.75 Hp motor.

Our machines do not require any maintenance.

All this guarantees a powerful, reliable and durable juicer. Without a doubt, a highly profitable investment.

The reviews throughout our history support us.



+30

Years of experience



+100

Countries present



+20.000

Satisfied customers

The search for the perfect juice as a goal and as a lifestyle.



Our **mission** is to design, develop, produce and market the most efficient, innovative and resistant range of juice squeezers that meet the strictest global standards of quality and sustainability, in order to provide the best freshly squeezed natural juice and satisfy consumers demand, which is based on a new lifestyle consisting of sustainability and health care.

Values that defines Zumoval are: commitment to our clients, creativity, passion for a job well done, innovation, the quality of our products and processes and the guarantee.

News



New Byw Fly system



New Push&Juice bottom to easily have fresh squeezed juice.



New appearance of waste bins

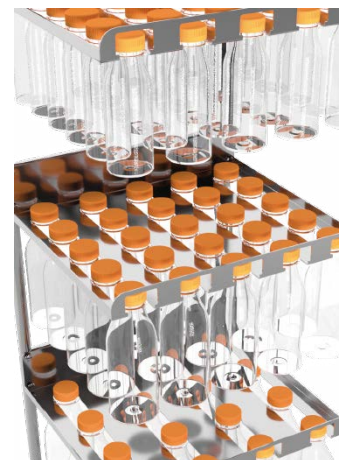

New T-Rack bottle stand

MINIMAX

The smallest juicer

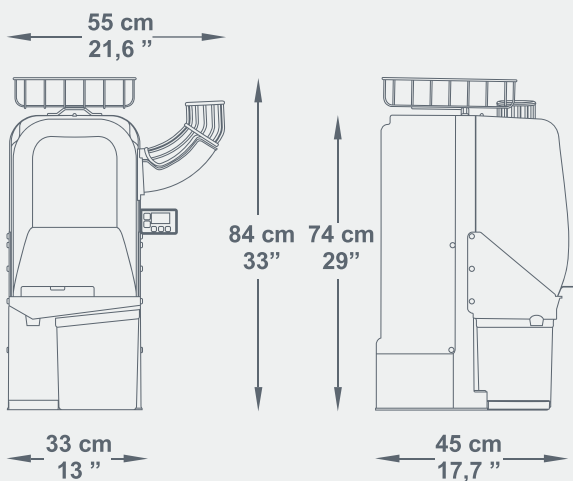

15
fruits/
minute

60 - 80 mm
2,36 - 3,15 "
diameter



The Minimax is the smallest juicer of our brand. You can squeeze oranges, tangerines, limes, lemons and other fruits between 65 and 80 mm in caliber, obtaining a freshly squeezed juice of the highest quality.

The Minimax is the perfect juicer for for shops with low or moderate consumption that have a limited space.

It has a capacity of 6 kg in the upper basket and 5 units in the feeder tube.

MINIMATIC

Small juicer with automatic feeder



Orange

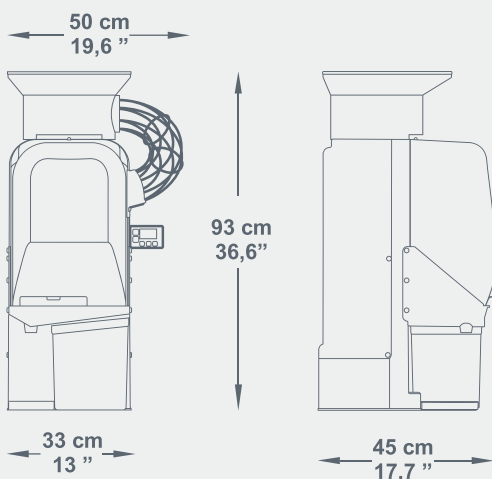

15
fruits/
minute

60 - 80 mm
2,36 - 3,15"
diameter

MINIMATIC



The Minimatic is our smallest juicer with automatic feeding. It is perfect for places of moderate consumption that have a reduced space such as small cafeterias, juice bars or tea rooms.

The Minimatic is capable of squeezing 15 pieces of fruit per minute, which is equivalent to one liter of juice. The machine offers great performance and quality of squeezing.

This juicer is equipped with a 6k feeder basket. It is also equipped with a unique stop-fruit system, which prevents entering fruits into the machine while cleaning.

OPTIONS

+ Self-Cleaning system

STANDS AND COUNTERTOPS

+ Mini Stand

+ Mini Countertop

BASIC

Compact with manual feeder



Orange



Lemon



Tangerine



Lime

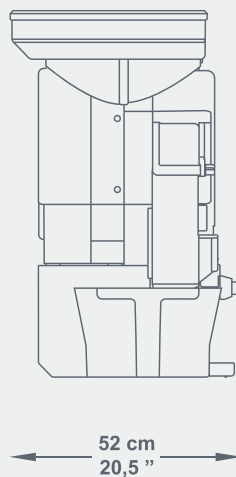
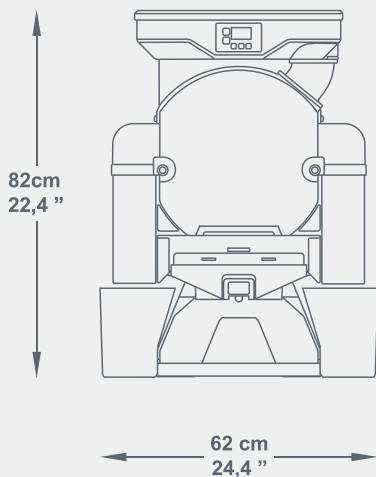

28
fruits/
minute

60 - 80 mm
2,36 - 3,15 "
diameter



The Basic juicer is perfect for places with medium consumption that wants to offer freshly squeezed juice of the highest quality.

Its manual feeder has a capacity of 8Kg of fruit in the upper basket and 8 pieces of fruit in the feeding ramp.

By combining the different options and accessories you can create the perfect juicer for your business.

OPTIONS

- + Self-Cleaning system
- + Squeeze Kit S

COUNTERTOPS

- + BT Countertop
- + BT Pulp-Out Countertop

BIGBASIC

Compact for big fruits



Orange



Pomegranate



Grapefruit



Lemon



Tangerine



Lime

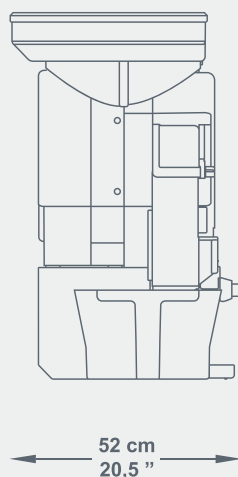
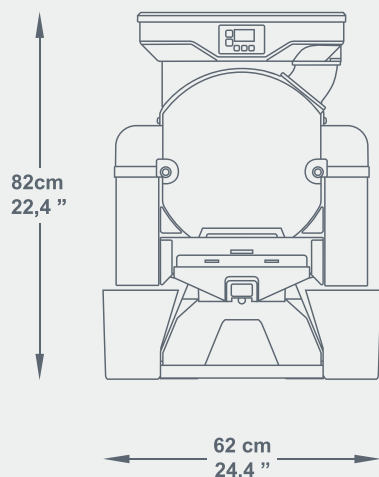

28
fruits/
minute

80 - 95 mm
3,15 - 3,74 "
diameter

BIGBASIC



The BigBasic is our large-caliber fruit juicer with a manual feeder system. This juicer is perfect for juice bars, workshops, hotels or restaurants.

The BigBasic is able to squeeze pomegranates, grapefruits, lemons, oranges and other citrus fruits with a diameter between 45 and 95 mm.

It can be installed on a countertop and options can be added according to your needs.

OPTIONS

- + Self-Cleaning system
- + Squeeze Kit S
- + Squeeze Kit M

COUNTERTOPS

- + BT Countertop
- + BT Pulp-Out Countertop

TOP

Fast with automatic feeder



Orange



Lemon



Tangerine



Lime

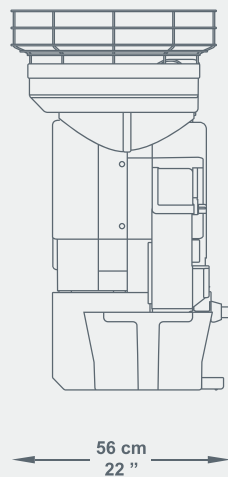
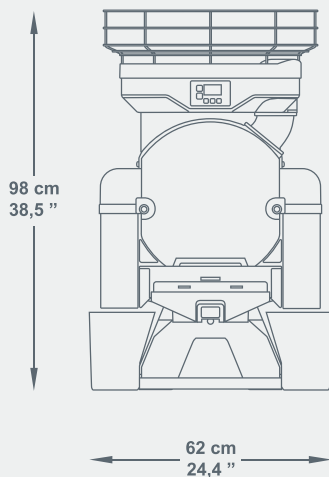

28
fruits/
minute

60 - 80 mm
2,36 - 3,15 "
diameter



With a squeezing speed of 28 pieces of citrus fruits per minute, the Top allows you to obtain, in just a few seconds, a freshly squeezed juice of the best quality.

The Top has been specially designed for places with medium-high consumption, such as bars, restaurants, hotels or supermarkets. It offers a wide range of furniture, countertops and options to combine, which allow it to adapt to any environment or need.

Thanks to the unique squeezing system, it allows you to obtain the maximum yield from the citrus without losing properties or altering the flavor.

OPTIONS

- + Self-Cleaning system
- + Automatic filter
- + Squeeze Kit S
- + Bye Fly system
- + Bottle Holder

ACCESSORIES

- + Bottle rack
- + Water Pump system

STANDS AND COUNTERTOPS

- + Service stand
- + Dispenser stand
- + Frigo stand
- + BT Countertop
- + BT Pulp-Out Countertop

FASTTOP

The fastest juicer



Orange



Lemon



Tangerine



Lime

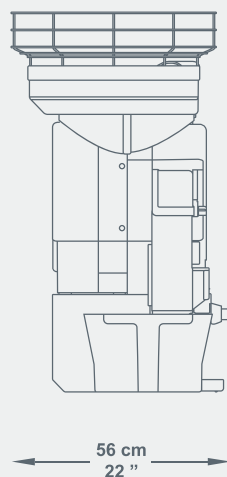
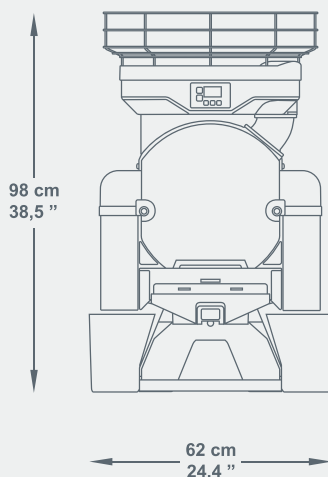

45
fruits/
minute

60 - 80 mm
2,36 - 3,15"
diameter



The FastTop is the fastest and most performant automatic juicer.

The machine is capable of squeezing up to 45 oranges per minute, which is equivalent to 3 liters of juice per minute approx.

It is the perfect juicer for places with high consumption such as supermarkets, hotels, restaurants, small juice factories or airports.

It allows you to configure the perfect juicer for your business since it accepts multiple options, accessories, stands and countertops.

OPTIONS

- + Self-Cleaning system
- + Automatic filter
- + Squeeze Kit S
- + Bye Fly system
- + Bottle Holder

ACCESORIES

- + Bottle rack
- + Water Pump system

STANDS AND COUNTERTOPS

- + Service stand
- + Dispenser stand
- + Frigo stand
- + BT Countertop
- + BT Pulp-Out Countertop

BIGTOP

Fast and powerful for large fruits



Orange



Pomegranate



Grapefruit



Lemon



Tangerine



Lime

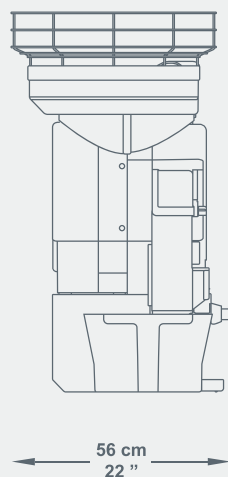
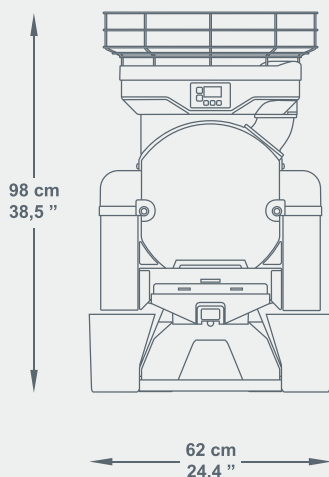

28
fruits/
minute

80 - 95 mm
3,15 - 3,74 "
diameter



Our BigTop juicer is the perfect juicer for large-calibre fruits, as it combines the best features of our top juicer but allowing a higher squeezing caliber, perfect for large-caliber oranges, pomegranates and grapefruit.

The BigTop is a versatile juicer allowing you to squeeze fruits from 45-95 mm by just changing the squeezing unit.

The perfect juicer for juice bars, supermarkets or production lines.

Combined with the multiple options available, it allows you to set up a strong, versatile and powerful juicer.

OPTIONS

- + Self-Cleaning system
- + Automatic filter
- + Squeeze Kit S
- + Squeeze Kit M
- + Bye Fly system
- + Bottle Holder

ACCESORIES

- + Bottle rack
- + Water Pump system

STANDS AND COUNTERTOPS

- + Service stand
- + Dispenser stand
- + Frigo stand
- + BT Countertop
- + BT Pulp-Out Countertop

OPTIONS & ACCESSORIES



Self-Cleaning System

This option provides a single or double flushing system which cleans quickly the juicing area, saving both time and labour cost.



Automatic Filter

New filtering system which transports automatically seeds and pulp into the waste bin to obtain juice of the highest quality. Specially designed for self-service with high consumption



Squeezing kits S & M

Easily interchangeable kits that allow smaller calibres to be squeezed.

Kit S: 45-60 mm / 1,77-2,36 ”

Kit M: 60-80 mm / 2,36-3,15 ”



Bye Fly system

Innovative system that generates a current in the juicing area, preventing fruit insects from accessing and contaminating the juice.



Bottle holder

Accessory designed to adapt to the Stainless Steel Self-Tap and allow the filling of bottles without having to hold them.



Juice level detector

System to have always a fixed amount of juice in the tank. When opening the tap, the machine automatically starts squeezing to fill the tank up to the level of the detector. Only available with Dispenser Stand or Frigo Stand.



Bottle stand

Available in two configurations: cabinet-mounted bottle rack and T-Rack, an innovative dispensing system that optimizes bottle access and organization.



Water Pump system

The perfect solution for those users who wish to have the Self-Cleaning system but who lack a water intake close to the location of the juicer.

STANDS & COUNTERTOPS



Mini Stand
For moderate consumption.



Mini Countertop
To raise the juicer up to 13 cm / 5,11 Lbs

Minimatic



Service Stand
For high consumption in self-service mode.



Dispenser Stand
To always have freshly squeezed juice.



Frigo Stand
With a cooling tank to obtain juice at the desired temperature.

Top - FastTop - BigTop



BT Countertop
To raise the juicer up to 13 cm / 5,11 Lbs.



BT P-Out Countertop
Discharges the peels into the lower waste container provided

Basic - BigBasic
Top - FastTop - BigTop



Pol. Ind. Fuente del Jarro C/ Islas Canarias, 59
46988 PATERNA (Valencia, España)
Tel. +34 961 344 141
www.zumoval.com info@zumoval.com



2026v0 Version