

MINIMAX

CARACTÉRISTIQUES TECHNIQUES

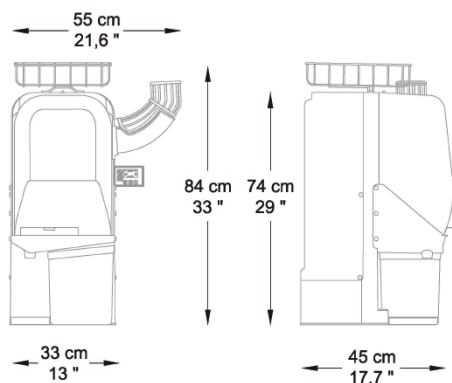

Fruits par minute	15
Capacité d'alimentation	6 Kg / 13,2 Lbs
Mode d'alimentation	Manuelle
Diamètre de pressage	65-80 mm / 2,56-3,15"
Poubelle d'écorces	9 Kg / 20 Lbs / 54 oranges pressées approx.
Poids	51,5 Kg / 113,5 Lbs
Tension	230 V - 50/60 Hz 115 V - 60 Hz
Consommation	3,7 A / 4,1 A 8,1 A
Puissance	550 W - 0,7 Hp
Protection	Detectores de seguridad y bloqueo. IPx4
Consommation recommandé	🔥🔥🔥 Modéré



OPTIONS



+ Grifo Self Inox

Facile à utiliser, en tournant le robinet, la machine commence à presser les oranges. Le robinet permet le remplissage en mode continu et mode discontinu.



+ Système autonettoyant

Système automatique pour un lavage rapide et intensif de la zone de pressage.



COULEURS

