

MINIMATIC Mini

CARATTERISTICHE TECNICHE

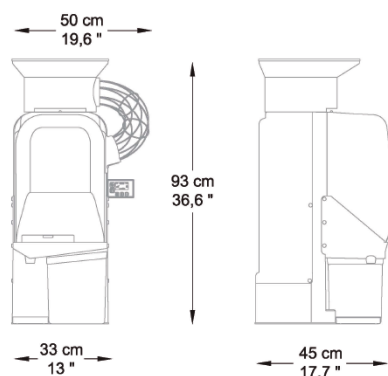

Frutti al minuto	15
Capacità dell'alimentatore	8 Kg / 17,6 Lbs
Tipo di alimentatore	Automatico
Diametro di spremitura	65-80 mm / 2,56-3,15"
Deposito di bucce	9 Kg / 20 Lbs / 54 arance spremute circa
Peso	53,3 Kg / 117,5 Lbs
Tensione	230 V - 50/60 Hz 115 V - 60 Hz
Consumo	3,7 A / 4,1 A 8,1 A
Energia	550 W - 0,7 Hp
Protezione	Rilevatori di sicurezza e di chiusura. IPx4
Consumo consigliato	🍊🍊🍊 Moderato



OPZIONI



+ Rubinetto Inox Self Service

Rubinetto in acciaio inossidabile per il riempimento continuo e discontinuo di bottiglie.



+ Sistema di autopulizia

Sistema automatico per il lavaggio rapido e intensivo della zona di spremitura.



COLORI

