

BIGBASIC

TECHNICAL FEATURES

Fruits per minute	28
Feeder capacity	8 Kg / 17,6 Lbs
Feeder mode	Manual
Squeezing diameter	75 - 90 mm / 3 - 3,5"
Waste bin capacity	12 Kg / 26,5 Lbs / 72 squeezed oranges approx.
Weight	50,3 Kg / 110,9 Lbs
Voltage	230 V - 50/60 Hz 115 V - 60 Hz
Energy consumption	3,7 A / 4,1 A 8,1 A
Power	550 W - 0,7 Hp
Protection	Security and locking detectors. IPx4
Recommended consumption	👉👉👉 Medium

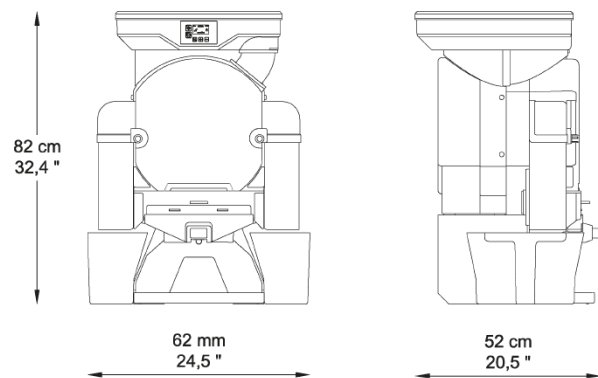

OPTIONS



+ Self-Cleaning system

Automatic double shower system for fast and intense cleaning of the squeezing area.

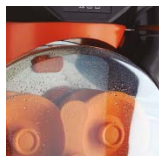

+ Automatic double action filter

Transports automatically seeds and pulp into the waste bin.



+ Pulp-Out Filter & Stainless Steel Self-Tap

Allows you to swipe seeds and pulp directly into the waste bin, by just sliding the Pulp-Out sweeper to the side.



ACCESSORIES



+ Bottle holder

Support for filling bottles without having to hold them.



+ Squeezing kits S & M

45-60 mm or 65-80 mm juice squeezing kits to process smaller calibre fruits.



COLORS

