

FASTTOP

CARATTERISTICHE TECNICHE

Frutti al minuto	45
Capacità dell'alimentatore	25 Kg / 55 Lbs
Tipo di alimentatore	Automatico
Diametro di spremitura	60-80 mm / 2,36-3,15 "
Deposito di bucce	12 Kg / 26,5 Lbs / 72 arance spremute circa.
Peso	51,5 Kg / 113,5 Lbs
Tensione	230 V - 50/60 Hz 115 V - 60 Hz
Consumo	3,7 A / 4,1 A 8,1 A
Energia	550 W - 0,7 Hp
Protezione	Rilevatori di sicurezza e di chiusura. IPx4
Consumo consigliato	🔥🔥🔥 Alto

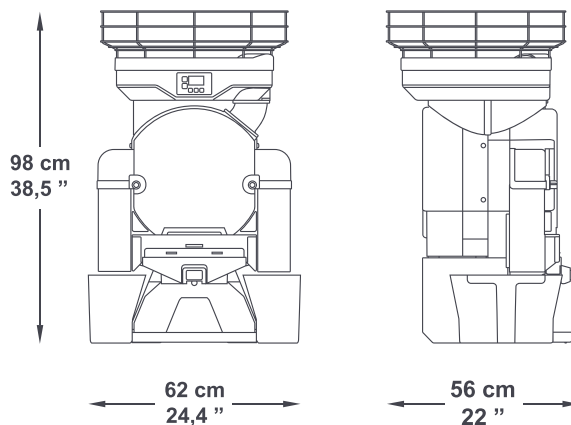

OPZIONI



+ Sistema di autopulizia

Sistema automatico a doppia doccia per un lavaggio rapido e intensivo della zona di spremitura.

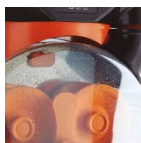

+ Filtro automatico doppia azione

Rimuove automaticamente i semi e la polpa nei contenitori delle bucce.



+ Sistema ByeFly

Il nuovo sistema crea una corrente d'aria nella zona di spremitura che la mantiene pulita da zanzare o mosche.

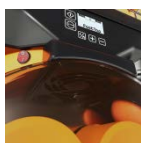

ACCESORI



+ Sostegno delle bottiglie

Supporto per riempire le bottiglie senza doverle tenere in mano.



+ Kit di Spremitura S

Kit opzionale da 45-60 mm per la spremitura di piccoli agrumi.



COLORI

