

# TOP Dispenser

## TECHNICAL FEATURES

Fruits per minute	28
Feeder capacity	25 Kg / 55 Lbs
Feeder mode	Automatic
Squeezing diameter	65-80 mm / 2,56-3,15 "
Waste bin capacity	In the stand
Weight	91,8 Kg / 202,3 Lbs
Voltage	230 V - 50/60 Hz 115 V - 60 Hz
Energy consumption	3,7 A / 4,1 A 8,1 A
Power	550 W - 0,7 Hp
Protection	Security and locking detectors. IPx4

Recommended consumption  High

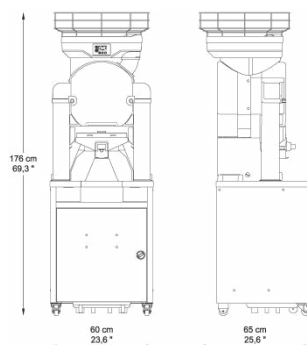

## COLORS



## Dispenser Stand



Stand equipped with a 5 liter juice dispenser with tap that allows to obtain freshly squeezed juice without having to wait.

Tank capacity	5 Liters
Waste bin capacity	50 Kg / 110 Lbs / 300 squeezed oranges approx.

## OPTIONS



**+ Juice level detector**

Automatic filling system that allows up to 5 liters of fresh juice to be permanently available.