

FASTTOP Service

TECHNICAL FEATURES

Fruits per minute	45
Feeder capacity	25 Kg / 55 Lbs
Feeder mode	Automatic
Squeezing diameter	65–80 mm / 2,56–3,15 "
Waste bin capacity	In the stand
Weight	95,4 Kg / 210,3 Lbs
Voltage	230 V - 50/60 Hz 115 V - 60 Hz
Energy consumption	3,7 A / 4,1 A 8,1 A
Power	550 W - 0,7 Hp
Protection	Security and locking detectors. IPx4
Recommended consumption	🔴🔴🔴 High

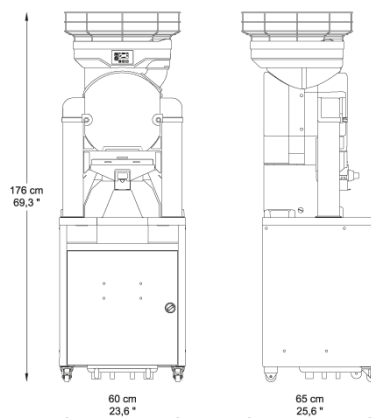

COLORS



+ Pulp-Out Filter & Stainless Steel Self-Tap

Service Stand



Support specially designed for places with self-service demand with high consumption.

With the Pulp-Out Filter & Stainless Steel Self-Tap option, seeds and pulp are easily removed to the waste bin.

A perfect solution to obtain the best quality juice.

Waste bin capacity	50 Kg / 110 Lbs / 300 squeezed oranges approx.
--------------------	--