

# FASTTOP Service

## TECHNICAL FEATURES

Fruits per minute	45
Feeder capacity	25 Kg / 55 Lbs
Feeder mode	Automatic
Squeezing diameter	65-80 mm / 2,56-3,15 "
Waste bin capacity	In the stand
Weight	92,5 Kg / 203,8 Lbs
Voltage	230 V - 50/60 Hz 115 V - 60 Hz
Energy consumption	3,7 A / 4,1 A 8,1 A
Power	550 W - 0,7 Hp
Protection	Security and locking detectors. IPx4
Recommended consumption	🔴🔴🔴 High

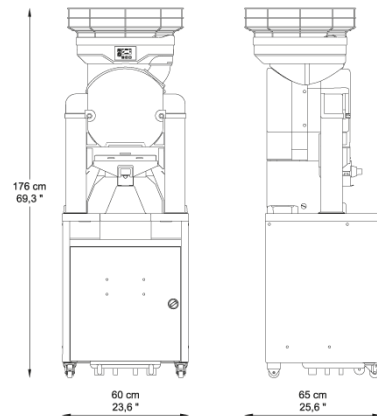

## COLORS



+ Automatic Double Action Filter

## Service Stand



Support specially designed for places with self-service demand with high consumption.

With the Automatic Double Action Filter the pulp and seeds are automatically transported into the waste bin.

Waste bin capacity	50 Kg / 110 Lbs / 300 squeezed oranges approx.
--------------------	--