

FASTTOP Frigo

TECHNICAL FEATURES

Fruits per minute	45
Feeder capacity	25 Kg / 55 Lbs
Feeder mode	Automatic
Squeezing diameter	65-80 mm / 2,56-3,15 "
Waste bin capacity	In the stand
Weight	100,3 Kg / 221 Lbs
Voltage	230 V - 50/60 Hz 115 V - 60 Hz
Energy consumption	3,7 A / 4,1 A 8,1 A
Power	550 W - 0,7 Hp
Protection	Security and locking detectors. IPx4

Recommended consumption  High

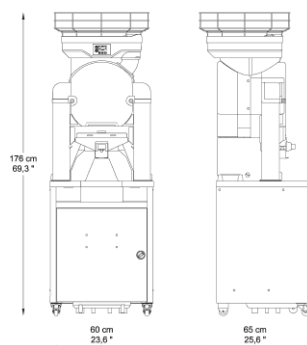

COLORS



Frigo Stand



Stand equipped with a 7 liter juice dispenser which is cooled by a cooling unit, which keeps the juice at the desired temperature. The best option to serve fresh and cold juice at all times.

Tank capacity	7 Liters
Waste bin capacity	33 Kg / 72,7 Lbs / 200 squeezed oranges approx.
Cooling device voltage	230 V - 50/60 Hz 110 V - 60 Hz
Cooling device consumption	1,4 A 4,2 A

OPTIONS



+ Juice level detector

Automatic filling system that allows up to 7 liters of fresh juice to be permanently available.